

> IEQ1020 230V

CARRELLO SOLLEVATORE

- Pedana con doppio pistone
- Piattaforma estensibile e livellabile
- Sistema di bloccaggio meccanico con azionamento elettrico
- Microinterruttore di fine corsa
- Piattaforma dotata di griglia da 10 cm con fori per l'installazione di accessori
- Progettata per l'installazione di batterie, motori, trasmissioni e sospensioni di veicoli elettrici

1200 KG

LIFTING TABLE

- Mobile lift table
- Extendable and levellable platform
- Mechanic lock system with electric releasing system
- Top limit switch maximum height
- Platform with threaded holes for accessories installation
- Designed for electric vehicles battery replacement, engines, transmissions and suspensions

TABLE ÉLÉVATRICE

- Table élévatrice mobile
- Plate-forme extensible et apte à être nivelé
- Système de verrouillage mécanique avec déclenchement électrique
- Interrupteur fin de course
- Plate-forme équipée d'une table à trous taraudés pour installation d'accessoires
- Conçu pour remplacement de batteries de véhicules électriques, moteurs, transmissions et suspensions

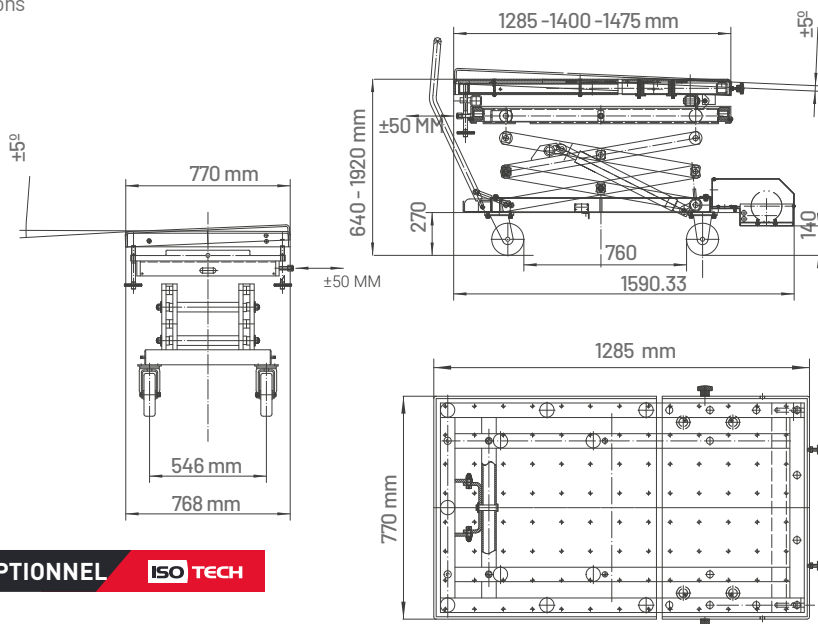

OPZIONALE - OPTIONAL - OPTIONNEL



DM1200-00AB

4 UDS



4 UDS

